

Section CS1, CS2

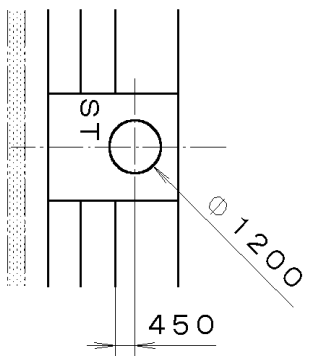

Section A-A

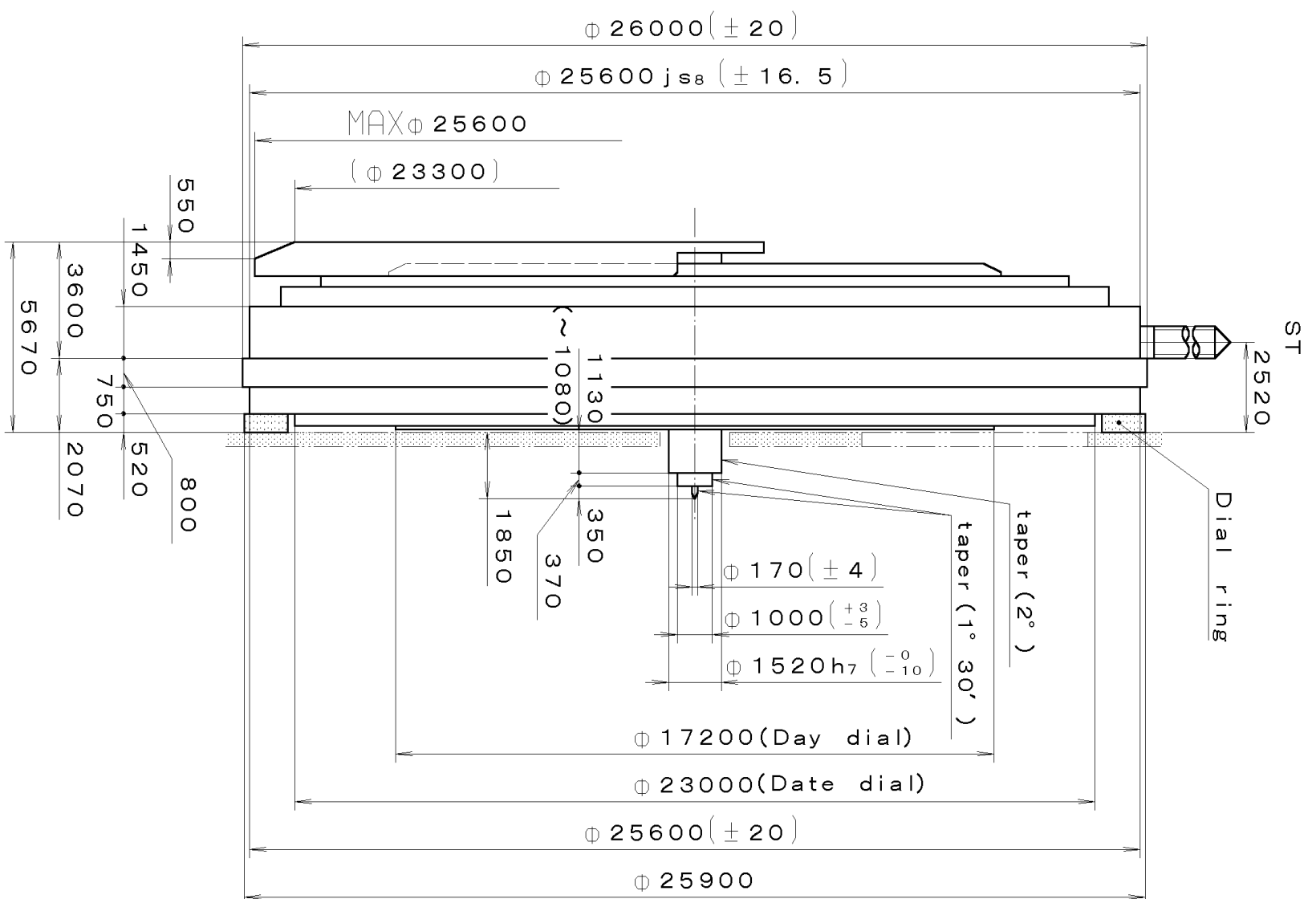

Material	Heat Treatment	Hardness	Plating	Quantity	Unit	Scale	Date	Drawn	Checked	Approved	Name:	Cal. No.:	Parts:
					1/1000 mm	6:1			T. Hiruta		Frame for Case	8205	
General Tolerances											Drawing No. : 8205C000		
Dimensions											MIYOTA		
Angles													

This drawing is provisional and subject to our reconfirmation and/or revision without notice.

*** T I P W 8205-AEB (01) *** (2100 1121) 02-03-11

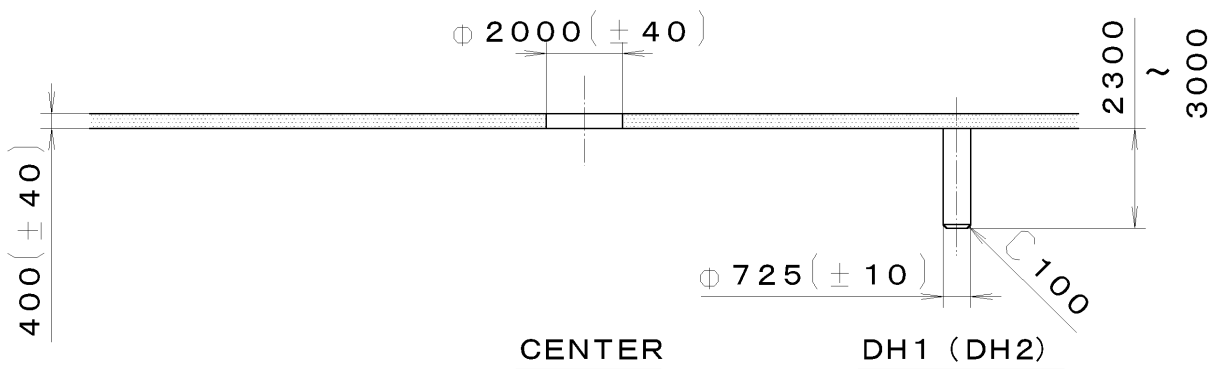
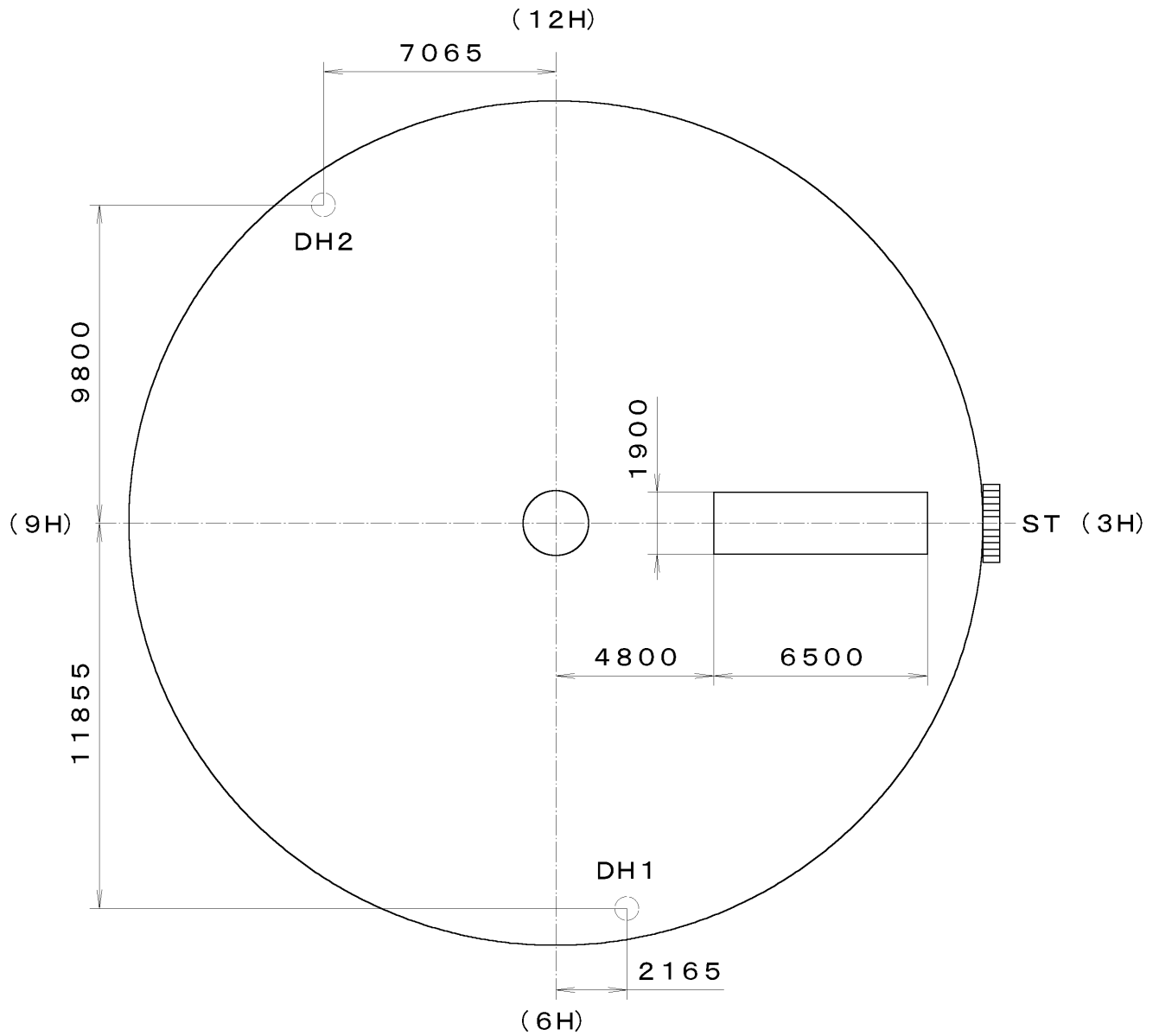

7			Quantity		Cal. No. :	8205-AEB
6			Unit	1/1000 mm		
5			Scale	5:1	Parts:	Name: Indications for Dial Drawing No. : 8205D001
4			Date			
3			Drawn			
2			Checked	T. Hiruta		
1			Approved			
Material						
Heat Treatment			General Tolerances			MIYOTA
Hardness			Dimensions			
Plating			Angles			

This drawing is provisional and subject to our reconfirmation and/or revision without notice.

*** T I P W (01) *** (2100 1121) 00-09-18

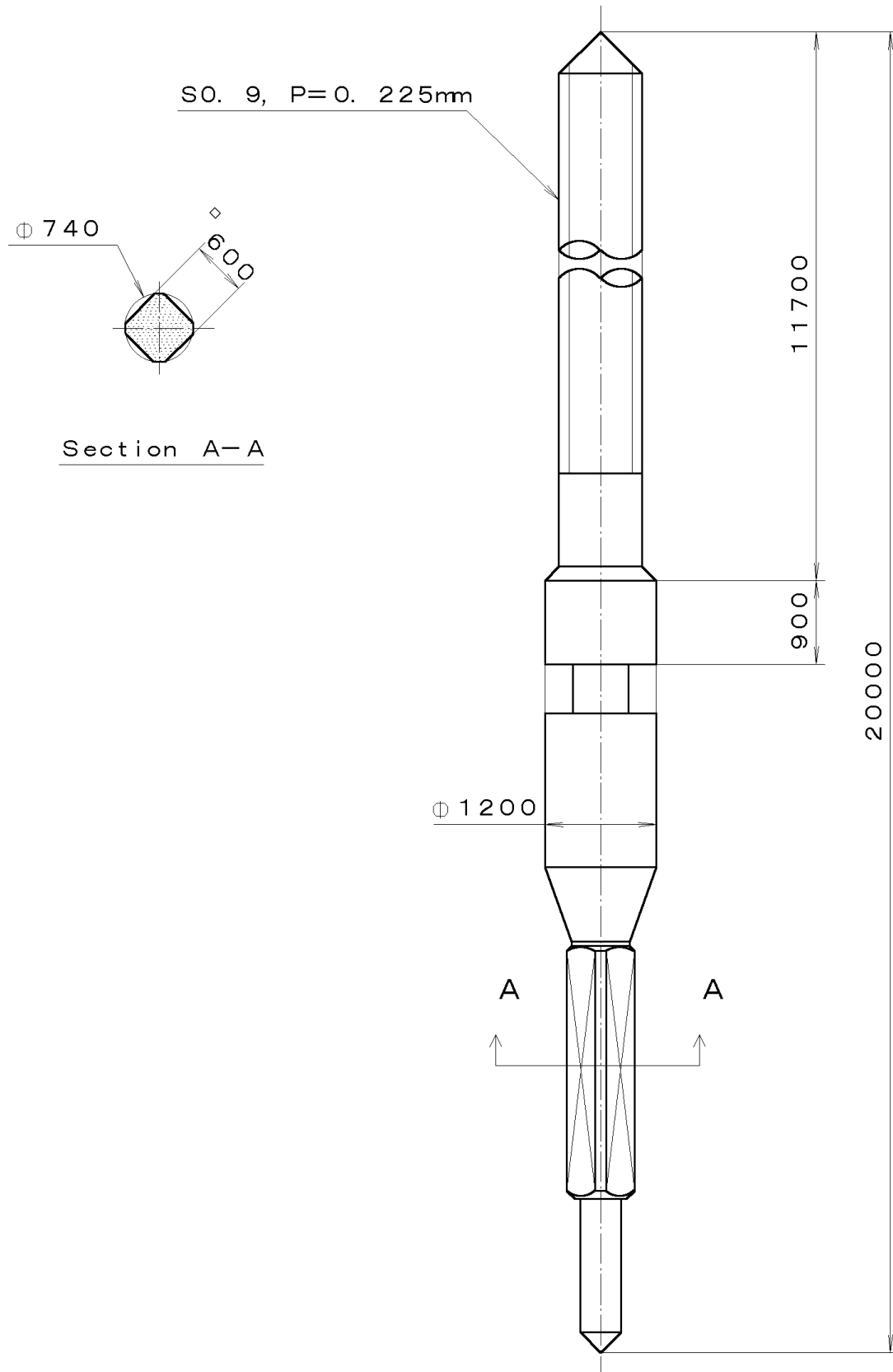

7			Quantity		Cal. No. :
6			Unit	1/1000 mm	
5			Scale	15:1	Parts:
4			Date		065-212
3			Drawn		
2			Checked	T. Hiruta	Name:
1			Approved		SETTING STEM
Material					Drawing No. : 2120S000
Heat Treatment			General Tolerances		MIYOTA
Hardness			Dimensions		
Plating			Angles		

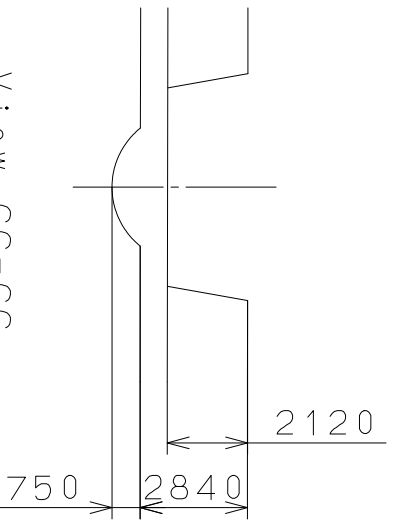
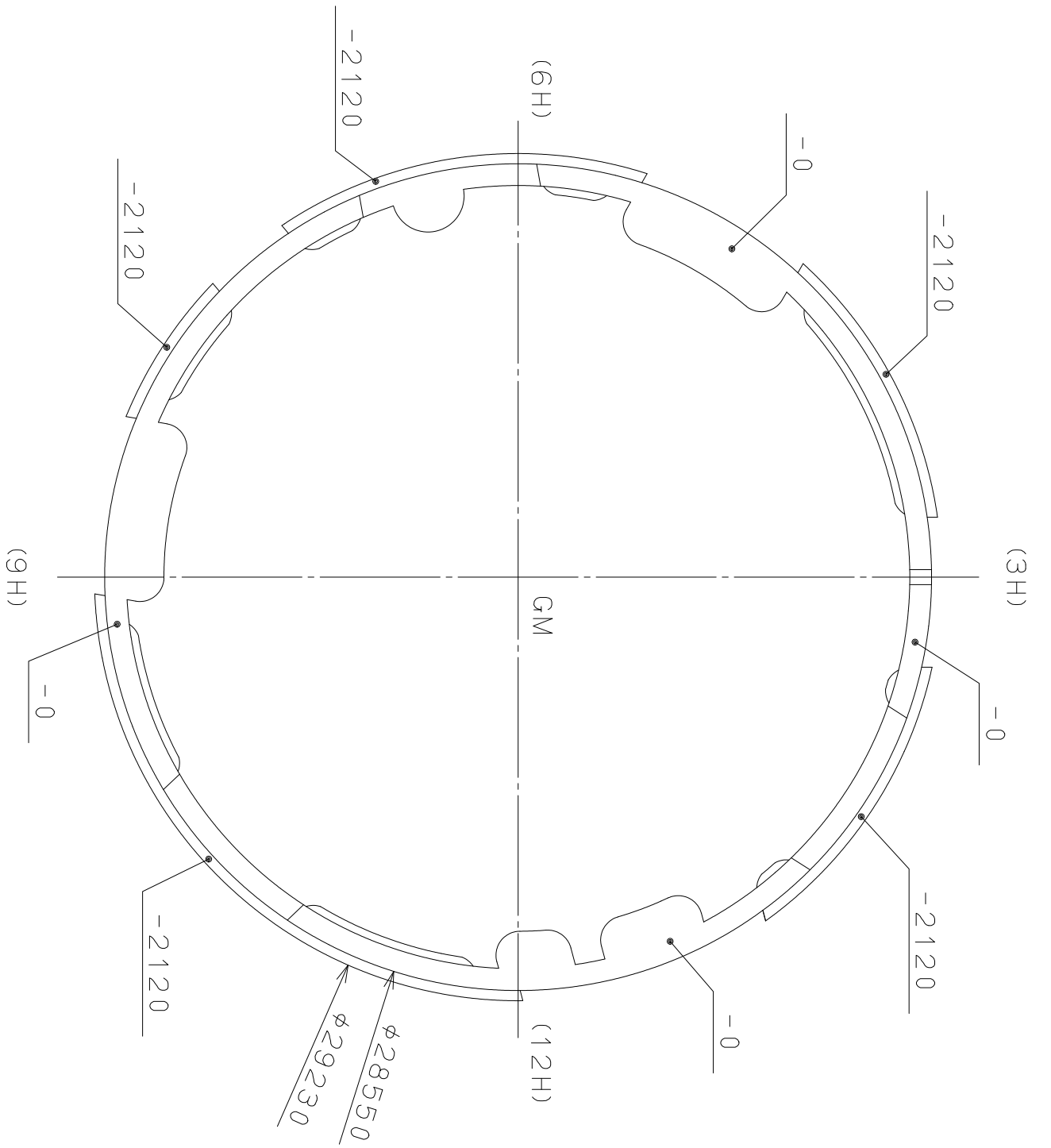

View CC-CC
DD-DD, EE-EE

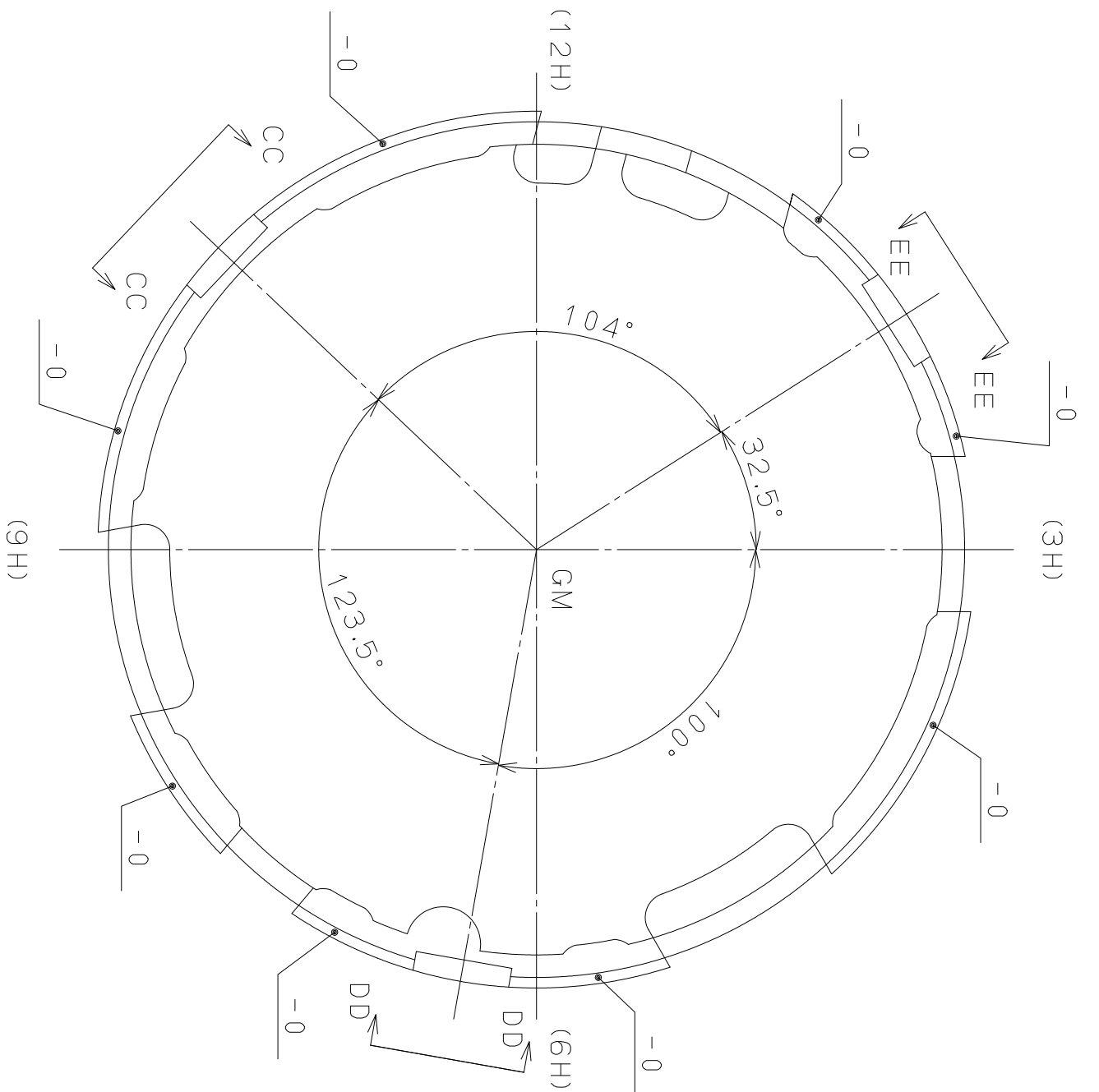

Quantity	1/1000 mm	Cal. NO.:
Unit	5 : 1	Parts No.:
Scale	Date	500-710
Drawn	Checked	Name:
Approved	N. Suzuki	Casing Holder
Material	Approved	Drawing No.: 8200E002
Heat Treatment	General Tolerances	MIYOTA
Hardness	Dimensions	
Plating	Angles	
CITIZEN WATCH CO., LTD. TOKYO, JAPAN		